

# 3S HEMI TOE IMPLANT SYSTEM

The 3S Hemi Implant System consists of a cobalt chromium (CoCrMo) implant to replace the articulating surface of the proximal phalanx of the first metatarsophalangeal joint and corresponding instrumentation to facilitate insertion.

## HEMI TOE IMPLANT

- Radiused, low profile anatomical head shape to allow for natural articulation and to provide the option of preserving host bone
- Tri-spade stem design intended to maximize stability and bone-to-implant contact for optimal osteointegration
- Sharp chisel-tip stem for simple initiation and placement
- Simple surgical technique for reduced OR time



## 3S HEMI IMPLANT SYSTEM

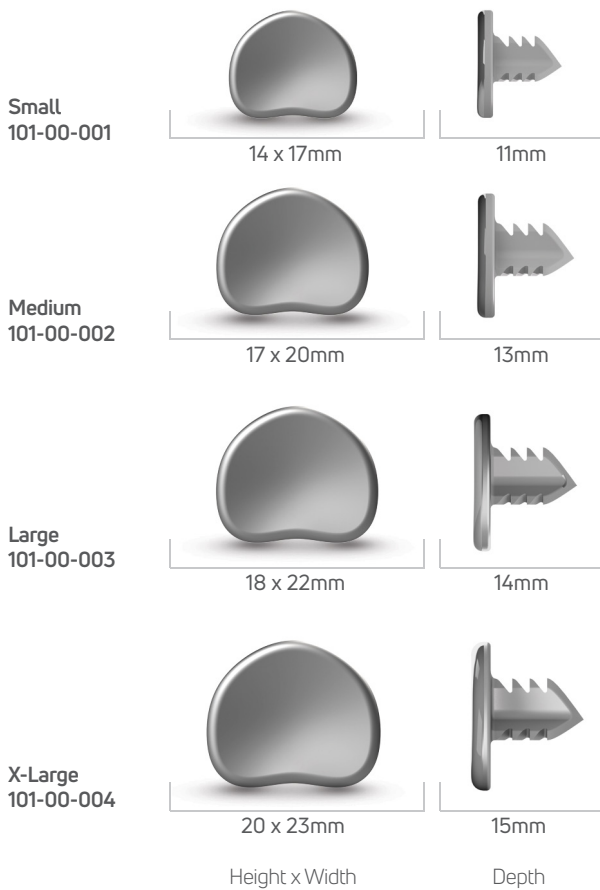

All associated instrumentation included in a single system

FDA cleared 510(k) K072922.  
Trilliant products are made in the U.S.A.



T 800.495.2919 F 877.778.3864  
727 North Shepherd Drive, Suite 100 | Houston, TX 77007 | U.S.A.  
djoglobal.com

Copyright © 2021 by DJO, LLC  
900-00-036 Rev H

Individual results may vary. DJO, LLC is a manufacturer of orthopedic implants and does not practice medicine. Only an orthopedic, or foot and ankle surgeon can determine what treatment is appropriate. The contents of this document do not constitute medical, legal, or any other type of professional advice. This material is intended for the sole use and benefit of the DJO, LLC sales force and physicians. It is not to be redistributed, duplicated, or disclosed without the express written consent of DJO, LLC. For more information on risks, warnings, and possible adverse side effects refer to the Instructions for Use provided with the device.

## SURGICAL TECHNIQUE



**STEP 1:** Expose the 1st metatarsal phalangeal joint with a 4cm to 5cm slightly curved dorsal incision just medial to the EHL tendon, allowing proper dissection to expose the joint capsule.

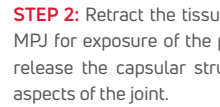

**STEP 2:** Retract the tissues, then incise the capsule with a "T" incision at the MPJ for exposure of the phalangeal base and the metatarsal head. Carefully release the capsular structures from the medial, dorsal, and anteriolateral aspects of the joint.

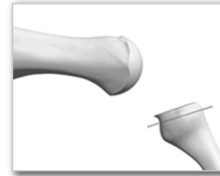

**STEP 3:** Resect the articular surface of phalanx with an oscillating or sagittal saw, making the cut perpendicular to the long axis of the phalanx. Resect only enough bone to avoid prosthetic overspacing and excessive joint tension by accommodating for proper implant head thickness (generally 2mm-8mm).

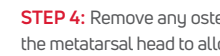

**STEP 4:** Remove any osteophytes from the lateral, dorsal, and medial aspects of the metatarsal head to allow for normal range of motion.

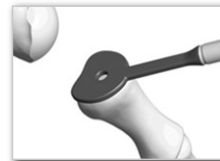

**STEP 5:** Determine implant size by application of implant sizers. Care should be taken to select sizer which approximates the dimensions of the osteotomized phalanx and does not extend beyond the margins of the cut surface.



**STEP 6:** Use the awl along with a mallet to create the guide hole.



**STEP 7:** Select corresponding color coded trial and insert into the osteotomized phalanx along the guide hole, using the impactor and a mallet if necessary. Reduce the joint and examine for tension and motion. A normal range of concentric, unimpinged motion particularly in dorsiflexion should be demonstrated. If the joint is too tight, remove the trial and resect the appropriate amount of bone from the proximal phalanx to relieve tension. An overly tight joint may result in limited motion and contraction hallux deformity post surgery. Final remodeling is performed to assure that the entire bone is covered by the trial.



**STEP 8:** Optional (for dense bone only): Place the appropriately sized broach into handle. Broach bone by aligning the spade tip with the center of the pilot hole created by the awl; "DORSAL" marking on broach bit indicates orientation. Use mallet if necessary



**STEP 9:** Once the appropriate size implant has been determined, the trial removed, and the metatarsal head remodeled, use the impactor to place the implant into phalanx until it is flush with the bone.

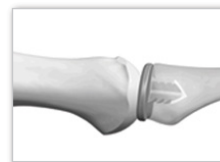

**STEP 10:** Once implant is placed, perform a final check of alignment and range of motion to ensure proper fit.

**STEP 11:** Irrigate and remove any debris from the joint space and close using standard closure techniques.